



LIMITED E-TENDER FOR SUPPLY, INSTALLATION, TESTING, COMMISSIONING AND MAINTENANCE OF CCTV SURVEILLANCE SYSTEMS ON TURNKEY BASIS FOR JORHAT MEDICAL COLLEGE & HOSPITAL, JORHAT AS PER EOI FLOATED VIDE NO. SMEJ/JMCH/2538/2021/2199 DATE: 11/05/2021

IFB NO. SMEJ/JMCH/2550/2021/3781 Date: 22/07/2021

TWO BID SYSTEMS

Date and Time of Publishing of Bid Document	12:00 PM of 23/07/2021
Date and Time of Site Survey	9.00 A.M of 26/07/2021 to 11.00 A.M of 28/07/2021
Date and time of Pre-Bid Meeting	12:00 PM of 28/07/2021
Date and Time of Start of Bid Submission	1:00 P.M of 29/07/2021
Date and Time of End of Bid Submission	12:00 PM of 13/08/2021
Date and Time of Opening of E-Technical Bid	1:00 PM of 13/08/2021
Tentative Date and Time of Opening of E-Price Bid	Shall be communicated only to the technically qualified bidders subsequently

Tender document may be downloaded from institute's web site www.jorhatmedicalcollege.in (for reference only) and e-portal site <https://assamtenders.gov.in>

Jorhat Medical College & Hospital, Jorhat

Kushal Konwar Path, Barbheta, P.O. Jorhat-785001, Assam, India

Email: jmc-asm@nic.in

www.jorhatmedicalcollege.in

Limited E-Tender- Supply, Installation, Testing, Commissioning and Maintenance of CCTV Surveillance System on Turnkey Basis for Jorhat Medical College & Hospital, Jorhat

NOTICE INVITING E-TENDER

Limited E - Tenders in two bid system through E-procurement solution are invited for supply, installation, testing, commissioning and maintenance of CCTV Surveillance Systems on Turnkey Basis for Jorhat Medical College & Hospital Jorhat. The bid is to be submitted online only on Public Procurement Portal www.assamtenders.gov.in as per finalization of EOI floated vide No. SMEJ/JMCH/2538/2021/2199 Date: 11/05/2021

The "Tender Document" comprise of General Instructions for Tender (Annexure-I), The Special instructions for Tender (Annexure-II) which will govern any contract made, Undertaking (Annexure-III) and Technical Specification (Annexure-IV) Comparative Technical Data Sheet (Annexure-VI).

Tenderers are requested that, before quoting their rates or submitting tender, the tender forms may please be read out thoroughly (line by line) so as to have a clear knowledge of the requirement contained therein, otherwise, the purchaser will not be held responsible for any such error/oversight of the tenderer and the penalties shall be levied for not complying with the requirements stated hereinor supply of the required item/services.

Details of the Tender

Name of Work	Limited E-Tender - Supply, installation, Testing, Commissioning and maintenance of CCTV Surveillance System on Turnkey Basis for Jorhat Medical College & Hospital Jorhat as per finalization of EOI floated vide No. SMEJ/JMCH/2538/2021/2199 Date: 11/05/2021
Date and Time of Publishing of Bid Document	23/07/2021 at 12 P.M
Date and Time of Site Survey	9.00 A.M of 26/07/2021 to 11.00 A.M of 28/07/2021
Date and Time of Pre-Bid Meeting	12:00 P.M of 28/07/2021
Date and Time of Start of Bid Submission	1:00 P.M of 29/07/2021
Last date and time for submission of e-tender	12:00 PM of 13/08/2021
Date & Time of Opening of Tender	13/08/2021 at 1 pm at Conference Hall, JMCH. In case the closing date is declared as holiday, tenders will be opened on the next working day. The time and venue shall remain unchanged.
Tender Fees (Non-refundable)	Rs. 1000/- in favour of "JMCH TENDER" payable at Canara Bank. Exemption only for Tender Fees & EMD will be acceptable for those vendors who have valid NSIC/MSME Certificate. Exemption will be acceptable for those vendors who have valid NSIC/MSME Certificate.
Earnest Money Deposit (EMD) Refundable	Rs. 20,000/- in favour of "JMCH TENDER" payable at Canara Bank, Jorhat Branch. Exemption will be acceptable for those vendors who have valid NSIC/MSME Certificate.
Performance security/Security Deposit Money	A sum equivalent to 5% of the total bid value of the Contract

E-tender documents can be downloaded from the Public Procurement Portal - <https://assamtenders.gov.in/nicgep/app> . The Interested bidders required to be submitted their bids online through Public Procurement Portal - <https://assamtenders.gov.in/nicgep/app>. Last date for receipt of tender is **13/08/2021 till 12 P.M.** Tender will be opened on **13/08/2021 at 1:00 PM.** In case the above date falls to be holiday, the tender shall be opened on the next working day at the same time. Any corrigendum to this tender will be notified through the aforesaid websites only. The undersigned reserves the right to accept or reject any or all the bids without assigning any reason at any stage.

Sd/-

Principal cum Chief Superintendent,
Jorhat Medical College & Hospital, Jorhat

GENERAL INSTRUCTIONS**Procedure for Submission of E-Tenders / Bids**

The bidders require to submit their bids through E-Procurement Portal [https:// assamtenders. gov. in/nicgep/app](https://assamtenders.gov.in/nicgep/app) under two bid system i.e.

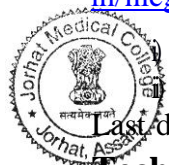
**Technical Bid and Financial Bid.**

Last date for receipt of tender is 13/08/2021 till 12 P.M. Tender will be opened on 13/08/2021 at 1 PM.

Technical Bid: -**Mandatory Documents**

The following documents must be uploaded for Technical bid

1. Demand Draft/FD for EMD of Rs. 20,000/-
2. Valid Trade License Certificate
3. Warranty Certificate for two/three years
4. PAN
5. GST Registration certificate
6. The bidder should submit duly notarized Manufactures' Authorization Form (MAF) from the OEM along with the tender.
7. Valid ISI/CE/ISO/BIS certificate
8. Mandatory spare parts availability for five years Certificate
9. Name & Address of Service Centre in North East
10. Copy of PAN Card
11. A Certificate about satisfactory performance of the equipment duly authenticated by other existing users of the equipment
12. Copies of Purchase Orders (PO) and Completion Certificates (CC) of similar filed i.e. IP based surveillance system done by the firm for any government/PSU organizations
13. Comparison Data Sheet (Annexure VI)
14. Signed Undertaking (as in Annexure III)

Bids received and found valid will be evaluated by the JMCH to ascertain the best evaluated bid for the complete work/services under the specifications and documents. The bidder should take care to submit all the information sought by JMCH in prescribed formats. Incomplete, conditional, telephonic bids or tender uploaded after due date & time will not be considered and summarily rejected.

Financial Bid: -

1. Those bidders who have qualified in technical bid shall be entertained for the financial bid. The financial bid format is provided as BoQ, Supplementary BoQ along with this tender document at <https://assamtenders.gov.in/nicgep/app> . Bidders are advised to download this BOQ as it is and quote their Final amount including tax and other charges for Supply installation, commissioning and maintenance of CCTV Surveillance System at JMCH in the permitted column and upload the same in the financial bid. Bidder shall not tamper/ modify downloaded price bid template (BOQ) in any manner. In case if the same is found to be tempered/ modified in any manner, tender will be completely rejected and EMD would be forfeited and tenderer is liable to be banned. Financial bid will be evaluated as per service charge quoted by the bidders. Thus a bid which is substantially responsive and quotes minimum Service Charge shall be ranked as L-1 and so on. In case, quoting same service charges by more than one bidder, the selection of **L-1 agency will be made on the basis of higher turnover in the same order.**



2. PERIOD FOR WHICH THE OFFER WILL REMAIN OPEN AND PERIOD OF VALIDITY.

- i) All tenders should remain valid for acceptance for a period of 365 days from the date of opening of the tender.
- ii) Quotations qualified by such vague and indefinite expressions such as “subject to immediate acceptance”, “subject to prior sale” etc. will not be considered.

3. BID SECURITY/EARNEST MONEY:

The tenderer shall have to deposit a hardcopy of Technical Bid alongwith Court Fees (Rs. 8.25/-), Tender Fees of Rs. 1000/- (Non refundable) & EMD money of Rs. 20,000/- (Refundable), failing which the tender shall be rejected. The Tender Fees & EMD is to be paid by Demand Draft/FD drawn in favor of “**JMCH TENDER**” payable at **Canara Bank, Jorhat Branch. NO CHEQUES OR CASH WILL BE ACCEPTED.** In the event of the withdrawal/ revocation of tenders before the date specified for acceptance, the earnest money shall stand forfeited. A hardcopy of Tender Document (Technical Bid) alongwith Court Fee (Rs. 8.25/-), Fees & Earnest Money Deposit (EMD) to be sent by post/ delivered in hand to the O/o. Principal cum Chief Superintendent, Jorhat Medical College & Hospital, Jorhat before 12 P.M on 13/08/2021. Successful tenderers’ earnest money will be returned without any interest, after receipt of performance security from that tenderer. Earnest money furnished by all the unsuccessful tenderers shall be returned to them without any interest whatsoever, at the earliest after expiry of the final tender validity period but not later than 30 days after finalization of the contract.

4. OPENING OF TENDER:

The purchaser will open the tenders at specified date and time and at the specified place as indicated in the TENDER DOCUMENT. In case the specified date of tender opening falls on/ is subsequently declared a holiday or closed day for the purchaser, the tenders will be opened at the appointed time and place on the next working day. The TECHNICAL BID are to be opened in the first instance. These Tenders shall be scrutinized and evaluated by the competent committee/ authority with reference to parameters prescribed in the TENDER DOCUMENT. During the TECHNICAL BID opening, the tender opening official(s) will read the salient features of the tenders like brief description of the goods offered, delivery period, Earnest Money Deposit and any other special features of the tenders, as deemed fit by the tender opening official(s). Competent authority may call the tenderer for demonstration of technical specification. Thereafter in the second stage, the Financial Bid of only the technically acceptable offers shall be opened at a later date which will be notified to such tenderer.

5. PRICES

- i) Prices are to be quoted in Indian Rupees.
- ii) Prices quoted must be meaningful and measurable in the context.
- iii) Tenderers should clearly specify whether prices quoted are inclusive of GST / statutory charges or such charges as extra. Where no specific mention is made to GST/ or other duties, prices quoted shall be deemed to be inclusive of such taxes/ charges.
- iv) The price quoted by the tenderer shall not be higher than the lowest price charged by the tenderer for the goods of nature, class or description to a purchaser, domestic or foreign or any organization or Govt. department for last six months (enclosed necessary supporting document)

6. NOTIFICATION OF AWARD

Before expiry of the tender validity period, the purchaser will notify the successful



tender(s) in writing, by registered/ speed post or by fax / telex / cable (to be confirmed by registered/ speed post) that its tender for goods & services, which have been selected by the purchaser, has been accepted, also briefly indicating there in the essential details like description, specification and quantity of the goods & services and corresponding prices.

SECURITY DEPOSIT / PERFORMANCE SECURITY

On acceptance of the tender, within the period specified by the Principal cum Chief Superintendent, the successful tenderer/ contractor shall deposit a sum equivalent to 5% of security deposit, for due compliance & fulfillment of the terms and conditions of the contract. This has to be in the form of DD/FD drawn on any of the nationalized bank, in favor of JMCH TENDER A/c. No. 1154101023707, IFSC Code: CNRB0001154 payable at Canara Bank, Jorhat. **NO CHEQUES WILL BE ACCEPTED** for this purpose. On due performance and successful completion of the contract in all respects including warranty period, the security money deposit shall be returned to the contractor without any interest on presentation of an absolute. No Demand Certificate in the prescribed form and upon return in good condition of any other property belonging to the purchaser, which may have been issued to the contractor. If the contractor fails to do so, such failure will constitute a breach of the contract and the Principal cum Chief Superintendent shall be entitled to make other arrangements at the risk and expense of the contractor. Also, non performance/ unsatisfactory performance or violation of terms and conditions of the contract will make the contractor liable for forfeiture of security deposit. Then decision of the Principal cum Chief Superintendent shall be final and binding on this count.

8. DELIVERY TERMS

- a. Time and date of Delivery:- The time for and the date of delivery of stores/ date of execution of work as stipulated in the schedule shall be deemed to be the essence of contract and delivery/ execution must be completed not later than the date(s) specified. The delivery of the stores/ execution of work/ providing the service etc. are required to be completed within a period of four weeks of acknowledgement of order.

9. PAYMENT TERMS

- a. Payment shall be made after satisfactory inspection, installation and performance of the item/ equipment/ instrument subject to submission or appropriate and correct invoice, Challans and other documents as deemed fit.

10. OTHER TERMS

Responsibility for executing contract: The successful bidder would be entirely responsible for the execution of the contract in all respects in accordance with the terms and conditions as specified in the acceptance of tender.

- a. The Contractor shall not sublet/ transfer/ assign the contract/ any part thereof without the written permission of the Principal cum Chief Superintendent. In the event of the contractor contravening this condition, Principal cum Chief Superintendent shall be entitled to place the contract, elsewhere on the contractor's account at his risk and the contractor shall be liable for any loss or damage, which the Principal cum Chief Superintendent, JMCH Jorhat-Assam may sustain in consequence or arising out of such replacing of the contract.

Recovery of sums due: Whenever any claim for the payment of a sum of money arises out of or under this contract against the contractor the JMCH shall be entitled to recovery of such sum by appropriating, in part or whole the security / earnest money deposited by the contractor, when the balance or the total sum to be recoverable, as the case may be shall be deducted from any sum then due or which at any time thereafter may become due under this or any other contract with the JMCH. Should this sum not be sufficient to cover the full amount recoverable, the contractor shall pay to the JMCH

on demand the remaining balance due.

Insolvency and Breach of Contract: The Principal cum Chief Superintendent may at any time by notice in writing summarily terminate the contract without compensation to the contractor in any of the following events, that is to say:-



- If the contractor being an individual or if firm, any partner in the contractor's firm shall any time be adjudged insolvent or shall have a receiving order or orders for administration of his estate made against him or shall take any proceedings for liquidation or composition under any insolvency not for the time being in force or shall make any convenience or assignment of his efforts or enter in to any arrangement or composition with his creditors or suspend payment of bill if the firm be dissolved under partnership act.
- b. If the contractor being a company shall pass a resolution or court shall make an order for the liquidation of the affairs or a receiver of a manager on behalf of the debenture holder shall be appointed or circumstances shall have arisen which entitle the court or debenture holders to appoint a receiver or manager, or
 - c. If the contractor commits any breach of this contract not herein specifically provided for: Provided always that such determination shall not prejudice any right of action or remedy which have accrued or shall accrue thereafter to the purchaser and provided also that the contractor shall be liable to pay the purchaser for any extra expenditure, he is thereby put to, but shall not be entitled to any gain on goods & services.

Arbitration: In the event of any question, dispute or difference arising out of the terms and conditions listed down in this tender, the same shall be referred to Arbitrator appointed by The Principal cum Chief Superintendent. The procedure of the Arbitration will be governed by the provisions of Arbitration Act 1940 (as amended from time to time and rules framed there under)

Document: The tenderer should have a valid Trade license, PAN/GST Registration/ other statutory documents as applicable and produce attested copies of such certificates along with the tender papers in Technical Bid, failing which the tender shall be liable to be rejected.

Right to accept/ reject: The JMCH authority reserves the right to reject any or all tenders without assigning any reason whatsoever. Also, the hospital authority reserves the right to award any or part or full contract to any successful agency at its discretion and this will be binding on the tenders. The quantity shown in the tender can be increased or decreased by Principal cum Chief Superintendent to any extent depending upon the actual requirement.

Assistance to contractor: The contractor shall not be entitled to assistance either, in the procurement of raw materials required for the fulfillment of the contract or in the securing of transport facilities.

In case of failure to comply with the provisions of the terms and conditions mentioned, by agency that has been awarded the contract, the JMCH authority reserves the right to award the contract to the next eligible tenderer and the difference of price will be recovered from the defaulter agency who has been awarded the initial contract and this will be binding on the tenderer.

The Principal cum Chief Superintendent JMCH, Jorhat does not pledge himself to accept the lowest or any tender and reserve to himself the right of accepting the whole or any part of the tender or portion of the quantity offered and tenderer shall supply the same/ execute the work at the rate quoted.

Failure and Termination: If the contractor fails to execute the work or deliver the stores or any installments thereof within the period prescribed for such delivery (ie; within thirty days of award of contract), the Principal cum Chief Superintendent may without prejudice to his right to recover damages for breach of the contract, be entitled at his options:

- i. To recover from the contractor as agreed liquidated damages, a sum equivalent to 2% of the price of any stores which the contractor has failed to deliver within the period fixed for delivery for the schedule for each month or part of the month during which the delivery of such stores may be in arrears, where delivery thereof is accepted after expiry of the aforesaid period, or
- ii. To purchase from elsewhere, without notice to the contractor, on his account and at the risk of the contractor, the stores not delivered or stores of similar description (where stores

exactly complying with the particulars are not in the opinion of the Principal cum Chief Superintendent, JMCH Hospital Jorhat-Assam, readily procurable such opinion being final) without cancelling the delivery in respect of the consignments not yet due for delivery.

- iii. To cancel the contract or a portion thereof, and if so decided to purchase or authorize to purchase or stores not so delivered or other of a similar description (where stores exactly complying with the particulars are not in the opinion of the Principal cum Chief Superintendent, JMCH Jorhat-Assam, readily procurable such opinion being final) at the risk and cost of the contractor.



FORCE MAJEURE:

- a) Notwithstanding the provisions contained in Tender Document, the supplier shall not be liable for imposition of any such sanction so long the delay and/ or failure of the supplier in fulfilling its obligation under the contract is the result of an event of Force Majeure.
- b) For purpose of this clause, Force Majeure means an event beyond the control of the supplier and not involving the supplier's fault or negligence and which is not foreseeable and not brought about at the instances of, the party claiming to be affected by such event and which has caused the nn performance . Such events may include, but are not restricted to acts of the Purchaser/ Consignee either in its sovereign or contractual capacity, wars or revolutions, hostility, acts of public enemy, civil commotion, sabotage, fires, floods, explosions, epidemics, quarantine restrictions, strikes excluding by its employees, lockouts excluding by its management, and fright embargoes.
- c) If a Force Majeure situation arises, the supplier shall promptly notify the Purchaser / Consignee in writing of such conditions and thereof within twenty one days of occurrence of such event. Unless otherwise directed by the Purchaser / Consignee in writing, the supplier shall continue to perform its obligations under the contract as far as reasonably practical, and shall seek all reasonable alternative means for performance not prevented by the Force Majeure event.
- d) If the performance in whole or in part or any obligation under this contract is prevented or delayed by any reason of Force Majeure for a period exceeding sixty days, either party may at its option terminate the contract without any financial repercussion on either side.
- e) In case due to a Force Majeure event the Purchaser / Consignee is unable to fulfill its contractual commitment and responsibility, then the purchaser / Consignee will notify the supplier accordingly and subsequent actions taken on similar lines described in above sub-paragraphs.

Sd/-

Principal cum Chief Superintendent,
Jorhat Medical College & Hospital, Jorhat

SPECIAL INSTRUCTIONS FOR TENDER

The following special conditions shall apply for supply & Installation, testing, commissioning and maintenance of CCTV Cameras/Equipments/ Instruments etc at JMCH Jorhat-Assam.

**A. INSPECTION/ INSTALLATION OF ITEMS/ EQUIPMENTS:**

Supplies shall be accepted and work shall be certified as completed subject to satisfactory and complete installation (up to full potentials claimed for that respective equipment/Item) of the equipment/items supplied including supply of all accessories and certified by the assigned officer, and subsequent inspection by Principal cum Chief Superintendent, JMCH Hospital, Jorhat-Assam, Jorhat-Assam or his assigned representative. Any defect found in the materials/ equipment/ items supplied/ work done will render the supplies/work open to rejection and decision of the Principal cum Chief Superintendent, JMCH Hospital, Jorhat-Assam shall be final and legally binding. The tenderers shall have to take the same (rejected items) back at their own cost and risk, and shall replace such rejections with the items of standard specifications/ quality as acceptable to the Hospital Authority, Alternatively, the items may be purchased from others/ work may be executed through others, at the risks and costs of the tenderer, at the discretion of the authority.

B. WARRANTY/ GUARANTEE

Along with the Technical Bid, the following information is to be provided exclusively:

- i. The tenderer must quote the manufacturer/ brand of each equipment.
- ii. All the equipments shall be carrying Two/Three Years warranty/ guarantee against defects of manufacturer/ workmanship and poor quality of components. Accordingly the tenderer shall indicate clearly and exhaustively the mandatory warranty/ guarantee offered by them/ by the manufacturing/ supplying firms, its duration, as well as the various Terms & conditions involved therein, at the time of submission of the Technical Bid papers.
- iii. **The tenderer must be able to provide after sales service for the equipments quoted at least for a period of 5 (Five) years after the warranty period. A declaration on Rs. 100/-Non Judicial Stamp paper to such effect must be accompanied with the offer, in the technical bid.**
- iv. Uptime guarantee: During the warranty/ guarantee period the firm will maintain the equipments in good working condition. All the complaints will be attended by the firm within 2 (two) working hours of the dispatch of the complaint to their office. The firm shall ensure that machine/ cameras/ equipments/ installations etc. is set right within One day of the intimation. However, the tenderer have to arrange similar equipment as a standby at his cost and risk in case of breakdown. In case of the machine not being made functional within Three days, stiff penalty equivalent to 2% of the cost of machine per week shall be levied for every week of delay at the discretion of the authority. In addition, the tenderer have to arrange similar equipment as a standby as stated above.

C. SOFTWARE UPGRADATION:

Free up-gradation of software (all Update & Upgrades) at least for five years is to be provided wherever applicable. A notarized declaration on Rs.100/- Non Judicial stamp paper should be submitted.

D. SAMPLES/DEMONSTRATION

The firms should be prepared for onsite demonstration of items after the date of opening of tender for verification/inspection etc. to evaluate the quality of recording and video file outputs of the quoted CCTV equipment which to be notify later date as decided by the competent authority. The firm shall have to comply with such conditions failing which the tender shall be liable for rejection and forfeiture of the Earnest Money. The tenderer/firm/company shall arrange for demonstration of CCTV cameras and project/equipment/item/article at his own cost and risk. Tenderer who fails to demonstrate the equipments/ instruments quoted will not be considered for selection.



DETAILS OF ITEMS QUOTED:

It is mandatory to indicate the full name, make/ brand, model number, and detailed specification of the equipments quoted by them, (in addition, a brochure of product information may be attached along with). Tenderers also have to indicate clearly the Name, Address and all Contact numbers of the MANUFACTURING FIRM and firm responsible for providing AFTER SALES SERVICES of the equipment quoted by them.

- ii. The bidder should have adequate experience in the field of **Supply, Installation, and Testing & Commissioning of CCTV Surveillance System** for any government/ PSU organizations. (Copies of Purchase Orders (PO) and Completion Certificates (CC) should be attached for verification.)
- iii. **The bidder should have functional office set up inside the state Assam.**
- iv. The rate quoted by the bidder shall be inclusive of the charges like GST, transportation, installation, insurance, freight, clearance and loading or unloading at sites of JMCH. Rates quoted by the bidder shall be valid for a period of 365 days from the date of opening of the tender.
- v. **The Principal cum Chief Superintendent reserves the right to increase the quantity of goods as per actual measurement. The actual quantity of items to be finalized at the time of implementation CCTV surveillance system. Items mentioned in financial bid (BOQs) only for evaluation purpose.**
- vi. The delivery, installation and successful testing of the items must be completed within Forty Five days from the date of award of contract to the successful bidder.
- vii. Delivery period shall be specifically indicated in the tender and strictly adhered to. The supply will be arranged and made within the stipulated delivery period on receipt of the supply order. Any delay in the delivery period after the supply order is placed may result in cancellation of the supply order. In case the successful bidder became unable to supply within the time limit prescribed by the Principal cum Chief Superintendent, the supply order is likely to be cancelled and items will be arranged by Principal cum Chief Superintendent from elsewhere and the earnest money deposited along with security deposit collected from the successful bidder will be forfeited.
- viii. The Successful bidder within 7 days of getting confirmed award of contract has to enter into an agreement with the Principal cum Chief Superintendent, JMCH Hospital Jorhat-Assam in Rs.100/- non judicial stamp paper, to ensure warranty and after sales support during the warranty period.

UNDERTAKING:

- a) I, the undersigned certify that I have gone through the terms and conditions mentioned in the tender document and undertake to comply with them.
- b) The rates quoted by me are valid and binding upon me for the entire period of contract and it is certified that the rates quoted are the lowest quoted for any other institution/ hospital for last 6 months (enclosed necessary supporting documents).



The Tender Fees of Rs. 1000/- & earnest money of Rs. 20,000/- to be deposited by me has been enclosed herewithvide DD/FD No. _____ Dt _____, Drawn on bank _____, Branch _____.

- I hereby undertake to execute the items as per directions given in the tender document /supply order within stipulated period.
- e) I give the rights to Principal cum Chief Superintendent to forfeit the earnest money deposited by me/us if any delay occurs on my part or failed to supply/ install/testing/commissioning/maintenance of the CCTV Surveillance System etc. within the appointed time or the items of desired quality / specifications.
- f) There is no vigilance / CBI case or court case pending against the firm in Rs.10/- Non Judicial Stamp paper.
- g) Undertaking for Non Blacklisting duly notarized in a Rs. 10/- Non-Judicial Stamp paper.
- h) In case at any stage, it is found that the information given by me is false/incorrect, JMCH Hospital, Jorhat-Assam shall have the absolute right to take any action as deemed fit/without any intimation to me.

Date:-
Place:-

Signature of the tenderer:-
Full Name:-
Designation:-

(Office seal of the tenderer)



Sl. No.	Item	Minimum Specification
1	IP Bullet Camera	Fixed lens, 4MP, CMOS, Image Resolution:1920 x 1080 (Minimum), Camera Range: 50 Meter (Minimum), On-board storage, up to 128GBIR, Illumination: 0.014 Lux @(F1.4,AGC ON), H.265/H.264/MJPEG, H.265+/H.264+, Metal Casing, Motion Detection, Face detection, Built-in heater for Defog
	Veri Focal Camera	1/27” 2 MP Progressive Scan CMOS sensor, 0.03 lux@F2.0 (colour 1/30s, 30IRE0.009 lux@F2.0 (IR on), 3.6 MM (6mm,8mm OPTIONAL), H.265/ H.264+H.264H/MJPEG, 1920X1080/1280X960)/1280X720/704X576/704X480/VGA(640*480)/CIF (352X288/352X240), motion Detection, Privacy Mask, ICR, ROI, IR range of 80 Mtr,IP67, WDR
3	NVR (32 Channel)	Quad-core embedded processor, OS: Embedded Linux, HDMI and VGA output, Compression: Smart H.265+/H.265/Smart H.264+/H.264/MJPEG, Video resolution: 3840x 2160, 1920 x 1080, Video recording @320 Mbps, 6SATA ports upto 10 TB each, Support for eSATA disk, Support for multi-brand network cameras, ANPR, Face Recognition, SMD, Stereo Analysis
4	POE Switch	8/16 port Full PoE Gigabit Ethernet switch 2 SFP Uplink ports, 10/100/1000 MBps
5	CPU, Desktop	Core i5, 8GB RAM, 1 TB HDD, Windows 10
6	Monitor/Display	40” LED, HDMI, LAN, USB
7	UPS	3 KVA online UPS System with in-built battery, 30 minute backup
8	Connector	RJ 45 Connector
9	Storage	10 TB surveillance Hard Disk
10	Cable	Fiber Optic Cable (Single Mode) CAT 6 STP Cable
11	Accessories	Accessories for connecting OFC
12	Pipe	1 ½ inch PVC pipe
13	Housing	Housing and Enclosure for Outdoor camera
14	Rack	6U rack mountable with rail kit
15	Media Converter	Single mode 10/100

Note:

- All product brochures, technical documentation/specifications should be enclosed with
- All the above products should be of reputed brand, **ISI/CE/ISO/BIS** or any other required certification
- Warranty: - There should be onsite warranty of 2/3 years from the date of installation.

Maintenance: Annual Maintenance Contract [AMC] for 3 years from the date of expiry of the standard defect liability/warranty period of 2/3 years [from the date of successful commissioning of the security system]. The AMC charges, however, will include service charges only, and will exclude cost of the spare parts required for replacement. Yearly contract amount will be paid in advance on half yearly basis

Technical Specifications with Compliance Sheet

Sl. No.	Item	Minimum Specification	Make/Model	Compliance
1	IP Bullet Camera	Fixed lens, 4MP, CMOS, Image Resolution:1920 x 1080 (Minimum), Camera Range: 50 Meter (Minimum), On-board storage, up to 128GBIR, Illumination: 0.014 Lux @(F1.4,AGC ON), H.265/H.264/MJPEG, H.265+/H.264+, Metal Casing, Motion Detection, Face detection, Built-in heater for Defog		
2.	Veri Focal Camera	1/27" 2 MP Progressive Scan CMOS sensor, 0.03 lux@F2.0 (colour 1/30s, 30IRE0.009 lux@F2.0 (IR on), 3.6 MM (6mm,8mm OPTIONAL), H.265/ H.264+H.264H/MJPEG, 1920X1080/ 1280X960)/1280X720/704X576/704X480/VGA(640*480)/CIF (352X288/352X240), motion Detection, Privacy Mask, ICR, ROI, IR range of 80 Mtr,IP67, WDR		
3	NVR (32 Channel)	Quad-core embedded processor, OS: Embedded Linux, HDMI and VGA output, Compression: SmartH.265+/H.265/SmartH.264+/H.264/MJPEG , Video resolution: 3840x 2160, 1920 x 1080, Video recording @320 Mbps, 6SATA ports upto 10 TB each, Support for eSATA disk, Support for multi-brand network cameras, ANPR, Face Recognition, SMD, Stereo Analysis		
4	POE Switch	8/16 port Full PoE Gigabit Ethernet switch 2 SFP Uplink ports, 10/100/1000 MBps		
5	CPU, Desktop	Core i5, 8GB RAM, 1 TB HDD, Windows 10		
6	Monitor/Display	40" LED, HDMI, LAN, USB		
7	UPS	3 KVA online UPS System with in-built battery, 30 minute backup		
8	Connector	RJ 45 Connector		
9	Storage	10 TB surveillance Hard Disk		
10	Cable	Fiber Optic Cable (Single Mode) CAT 6 STP Cable		
11	Accessories	Accessories for connecting OFC		
12	Pipe	1 ½ inch PVC pipe		
13	Housing	Housing and Enclosure for Outdoor camera		
14	Rack	6U rack mountable with rail kit		
15	Media Converter	Single mode 10/100		

Comparative Technical Data Sheet

(Please refer Annexure – IV)

SI No	Particulars	Make offered	Deviation from Specifications,if any	Reason for Variation
1				
2				
3				
4				
5				
6				
7				
8				
9				
10				
11				
12				
13				



Signature & Seal of Bidder



Tentative Diagram of CCTV Surveillance System for Jorhat Medical College & Hospital

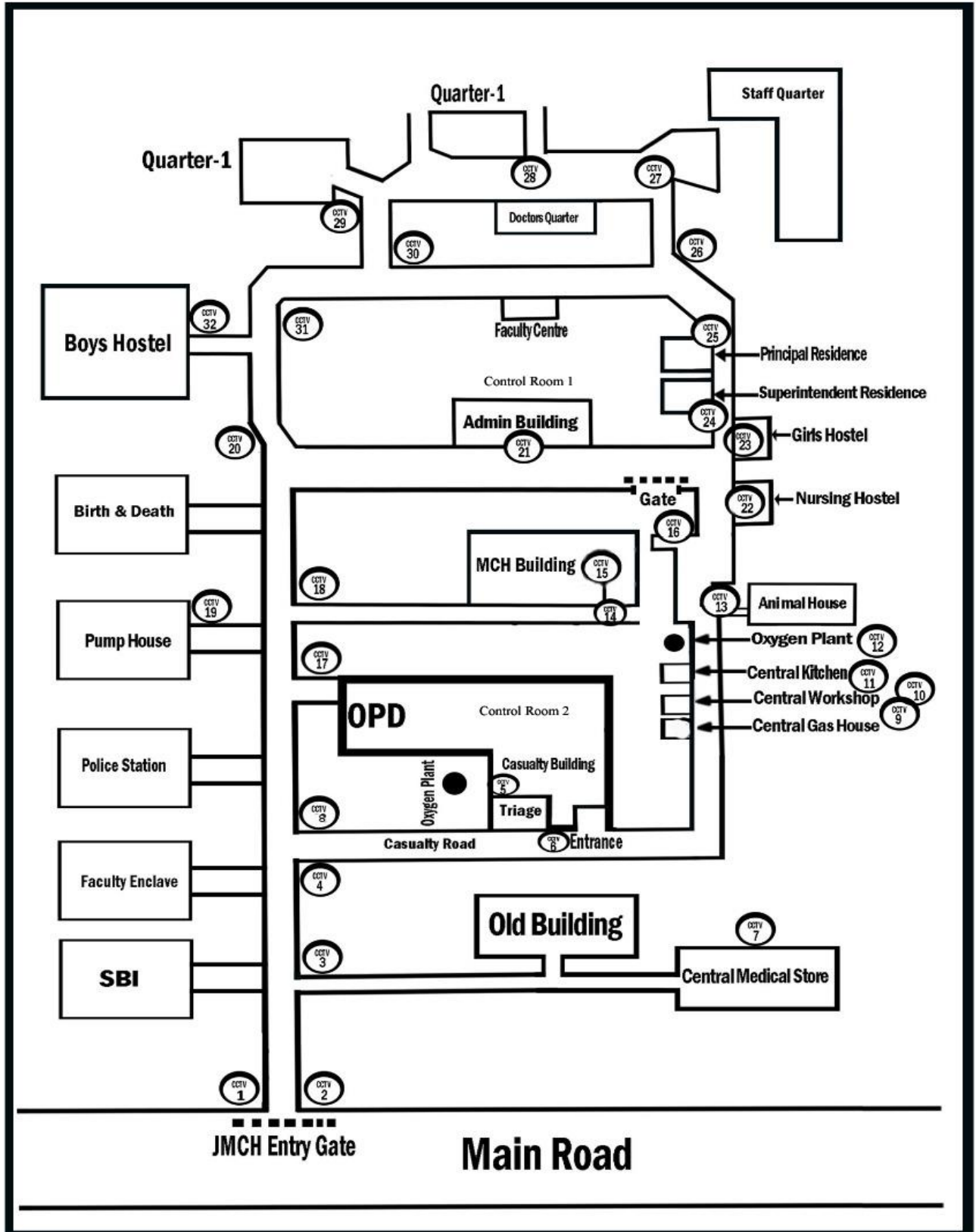

CCTV Surveillance System Design of Jorhat Medical College and Hospital (JMCH), Jorhat, Assam

The total design of the CCTV surveillance system of JMCH campus mainly includes three modules, namely:

- The main control room design,
- The sub-control room design and

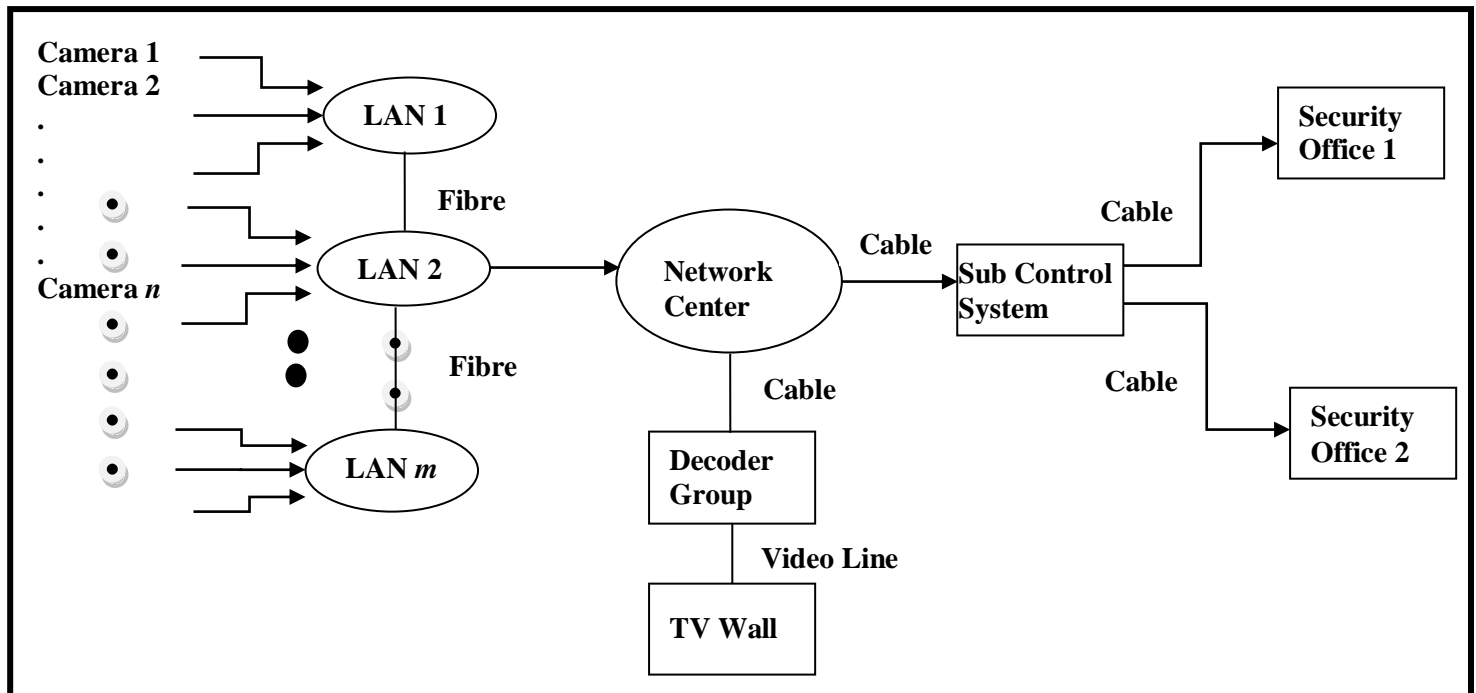

- The **Design of the Main Control Room**

The main control room design contains

- The **control system** of the **camera** and **display image** of the **surveillance points**
- The **design** of the **storage system**
- The **design** of the **sub - control room**
The JMCH planned to have two control rooms. The sub-control system computer installed with all necessary software and connected the campus network, can distribute and control the monitoring system in the sub-control points such as security office 1 and security office 2.
Main control center set the authorization management function to ensure strict monitoring system on the sub-control points.

The design of the surveillance points

Since of the cost, the fixed installation method is adopted, a color dome camera is intended to install in each spot.

- **Fixed installation is characterized by:**
The camera to monitor the distance and range will remain unchanged, not through the main control center for any control and regulation.

Equipment selection should fully guarantee to achieve monitoring without blind area, with clear image and voice.

Annexure - VII

Financial Bid

Format for Financial Bid

(As to be uploaded only in the standard format as BOQ, Supplementary BOQ for e-bidding at available in the e-procurement portal i.e: www.assamtenders.gov.in)

1. I/We have gone through the terms & conditions as stipulated in the tender enquiry document and confirm to accept and abide the same.
2. No other charges would be payable by the Institute.



Authorized signatory of the bidder with seal.